

8

7

6

5

4

3

2

1

- Item:
- ① Hold Down
 - ② Tray
 - ③ Bracket
 - ④ Retention Pin
 - ⑤ Mounting Holes

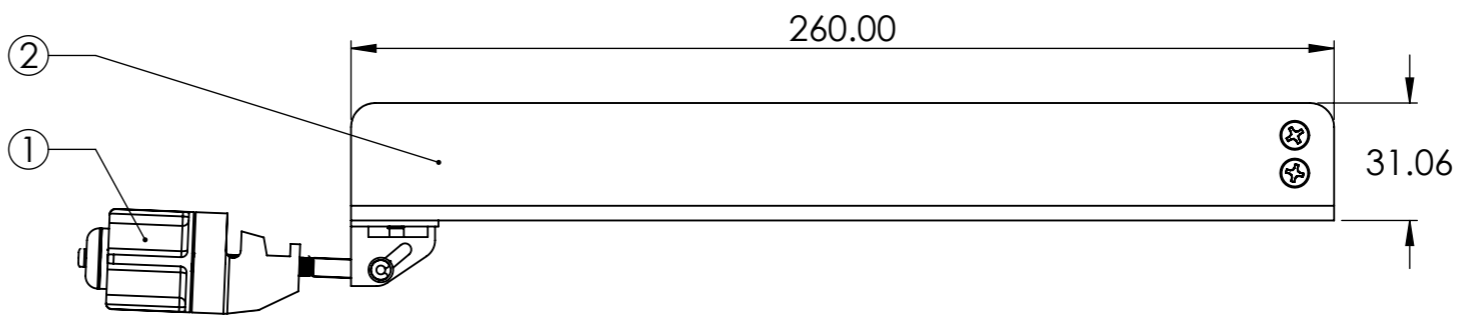
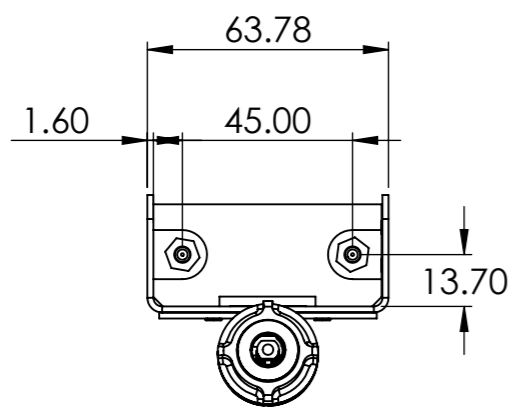
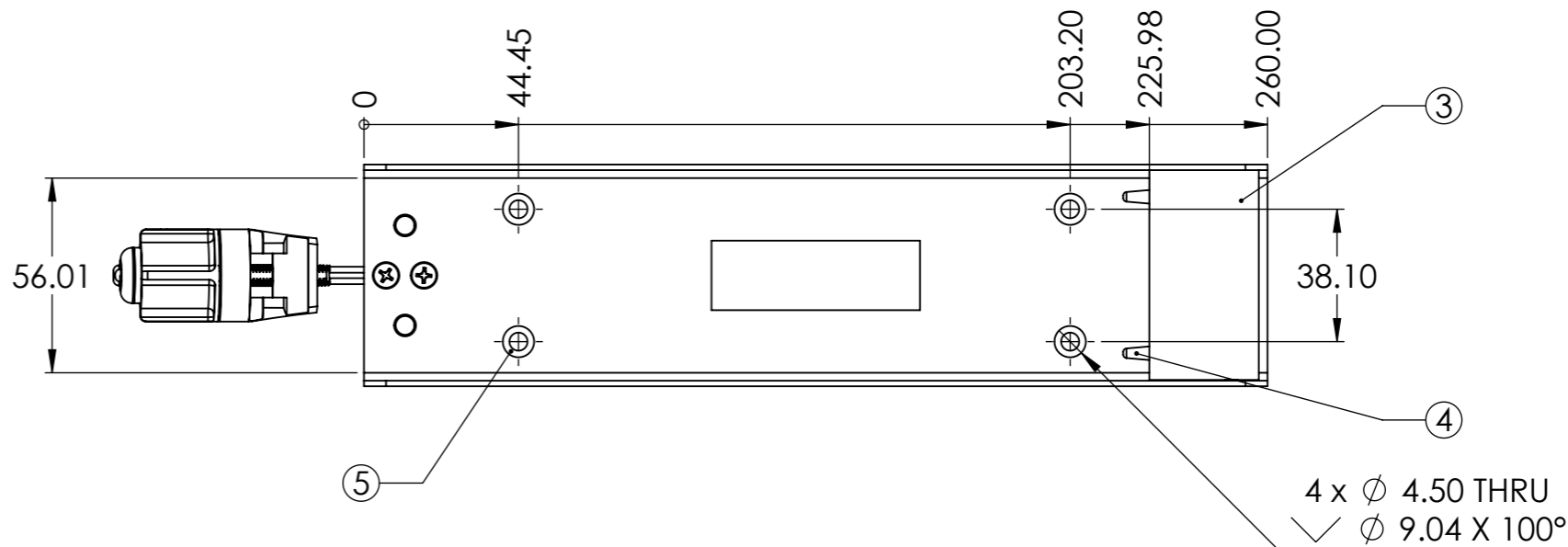
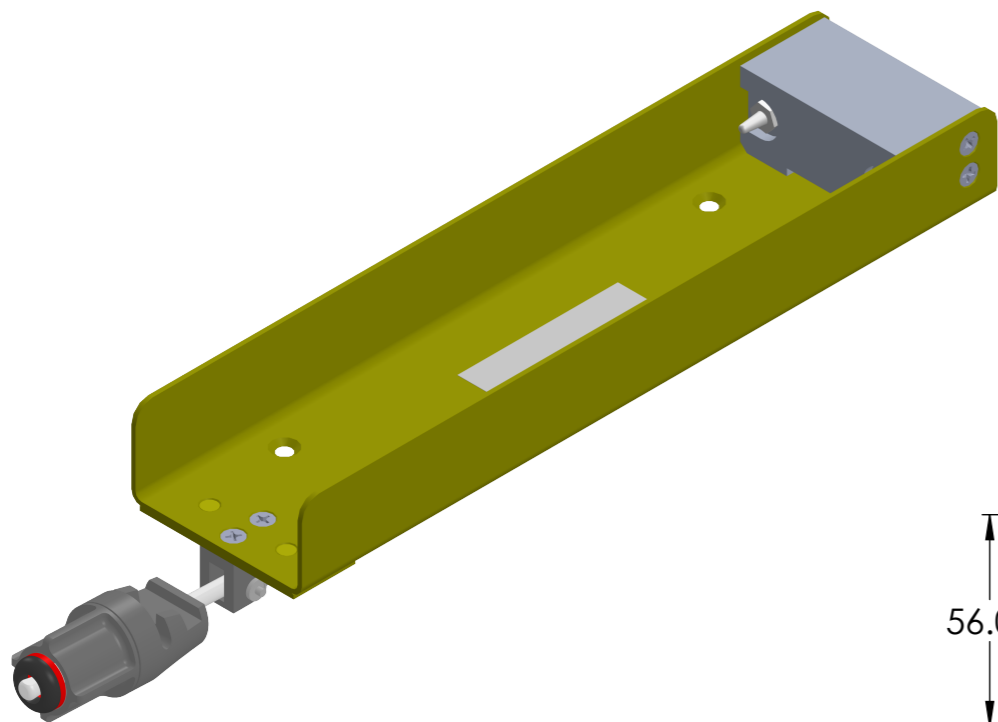

1.0	HW-2391	28/06/2023	JJB	RB
REV.	DESCRIPTION	DATE	DRAWN	APPV'D

Unless otherwise specified dimensions are in MILLIMETERS (mm) TOLERANCES: ISO 2768-m	Cage Code: EBL17	Flightcell International Ltd PO Box 1481, Nelson, New Zealand +64 3 545 8652 www.flightcell.com	TITLE: Flightcell 2 MCU DZMx Plus Tray Assembly General Arrangement Drawing		SHEET 1 OF 1
			DWG NO: 115-00017		
All finished parts supplied to these specifications shall be manufactured in compliance with EU Directive 2002/95/EC (RoHS) and other applicable standards. A certificate of conformance and a material declaration will be required for full part qualification.			ORIGINAL SCALE: 1:2 DRAWING SIZE: A3	CONFIGURATION: MEP_01-000	

8

7

6

5

4

3

2

1